

Gas Industry Standard

GIS/CW9:2020

Specification for

External Concrete Coatings



Use of these company logos only indicates membership of the ENA and does not imply that individual organisations have adopted either fully or in part the content of this document. Reference should be made to individual organisations to establish extent of adoption and any caveats or deviations.

Contents

Foreword	ii
Mandatory and non-mandatory requirements	ii
Disclaimer	ii
Brief history	iii
1. Scope	1
2. Normative references	1
3. Terms and Definitions	3
4. Health, Safety and Environment	3
5. Quality	3
6. General Requirements	3
7. Information Supplied by Purchaser	3
8. Materials	3
9. Concrete Mix	3
10. Coating Application	4
11. Curing Methods	4
12. Inspection and Testing	5
13. Repair of Coated Pipe	5
14. Markings	5
15. Handling, Storage and Transport	5
16. Test reports	5
Annex A – Health, Safety & Environment	6
Annex B – Quality	8
Annex C - Cathodic Protection - Anode Installation	9
1. General	9
2. Test procedures - Anodes and attachments	10
Annex D - Buckle Arresters	11
1. General	11
2. Test Procedures - Buckle arresters	13

Foreword

Gas Industry Standards (GIS) are revised, when necessary, by the issue of new editions. Users should ensure that they are in possession of the latest edition. Contractors and other users external to Gas Transporters should direct their requests for copies of a GIS to the department or group responsible for the initial issue of their contract documentation.

Comments and queries regarding the technical content of this document should be directed in the first instance to the contract department of the Gas Transporter responsible for the initial issue of their contract documentation.

This standard calls for the use of procedures that may be injurious to health if adequate precautions are not taken. It refers only to technical suitability and does not absolve the user from legal obligations relating to health and safety at any stage.

Compliance with this engineering document does not confer immunity from prosecution for breach of statutory or other legal obligations.

Mandatory and non-mandatory requirements

For the purposes of a GIS the following auxiliary verbs have the meanings indicated:

can indicates a physical possibility;

may indicates an option that is not mandatory;

shall indicates a GIS requirement;

should indicates best practice and is the preferred option. If an alternative method is used then a suitable and sufficient risk assessment needs to be completed to show that the alternative method delivers the same, or better, level of protection.

Disclaimer

This engineering document is provided for use by Gas Transporters and such of their contractors as are obliged by the terms of their contracts to comply with this engineering document. Where this engineering document is used by any other party, it is the responsibility of that party to ensure that the engineering document is correctly applied.

Brief history

First published as BGC/PSCW9: Part 1	August 1983
Amended issue published as GBE/CW9: Part 1	April 1993
Editorial update to reflect demerger November 2000	June 2001
Editorial update to reflect merger October 2002	November 2002
Editorial update to comply with GRM	July 2004
Amended and issued as GIS/CW9 combining Parts 1, 2 & 3	October 2020

© **ENA**, on behalf of Cadent Gas Limited, Gas Networks Ireland, National Grid, Northern Gas Networks, SGN, and Wales & West Utilities.

This Gas Industry Standard is copyright and must not be reproduced in whole or in part by any means without the approval in writing of either Cadent Gas Limited, Gas Networks Ireland, National Grid, Northern Gas Networks, SGN, or Wales & West Utilities.

1. Scope

This Specification is a supplementary to ISO 21809-5 and applies to bare steel pipes for use in pipeline transportation systems for the transmission and distribution of natural gas as defined in ISO 13623.

The external application of concrete is primarily used for the negative buoyancy of pipes used in buried or submerged pipeline systems and/or for the mechanical protection of the pipe inclusive of thrust bore application.

GIS/CW9 specifies the requirements for qualification, application, inspection, testing, handling and storage of materials required for the application of reinforced concrete coating in accordance with the published standard ISO 21809-5. It is a pre-requisite that ISO 21809-5 is reviewed in parallel with this Specification.

Additional / alternate requirements for testing, reinforcement, cathodic protection and buckle arresters are also specified insofar as they affect the finished concrete coating.

To ensure a consistent quality of the coated pipes and to avoid ambiguous and incomplete coating specifications in pipeline projects GIS/CW9 focuses on the execution and documentation of quality control, including detailed guidance to the specification of coating work.

This Specification should include the involvement of the Gas Transporter in quality control aspects, including review of procedures and inspection/testing plans for coating application, witnessing of qualification tests if deemed necessary by the Gas Transporter for coating and acceptance of documentation of quality control prior to start of production. The objective to ensure that the produced coating meets all requirements of this Specification and ISO 21809-5.



1. Concrete coatings shall be suitable for temperatures specified by the Gas Transporter.

If a new technology is available, it is the responsibility of the Contractor to identify any variations from this Specification and provide details.

2. Normative references

The following referenced documents are indispensable for the application of this document. For dated references, only the edition cited applies. For undated references, the latest edition of the referenced document (including any amendments) applies.

2.1 International Organisation for Standardisation (ISO)

ISO 10474, *Steel and steel products — Inspection documents*

ISO 13623, *Petroleum and natural gas industries — Pipeline transportation systems*

2.2 American Petroleum Institute (API)

API 5L, *Specification for line pipe*

2.3 British Standards

BS 427, *Method for Vickers hardness test and for verification of Vickers hardness testing machines*

BS 4515 -1, *Specification for welding of steel pipelines on land and offshore Part 1: Carbon and carbon manganese steel pipelines*

BS 5135, *Specification for metal-arc welding of carbon and carbon manganese steels*

BS 9001, *Quality management systems – Requirements*

BS EN 10045, *Charpy impact test on metallic materials*

2.4 Gas Industry Standard (UK)

GIS / CW5, *Field applied external coatings for buried pipework and systems*

GIS/CW6, *Specification for the external protection of steel line pipe and fittings using fusion bonded powder and other coating systems - requirements and methods of test for coating materials and factory applied coatings*

T/SP/PIP/1, *Specification for steel line pipe for natural gas pipelines operating at pressures greater than 7 bar (with specific requirements to BS EN ISO 3183:2012 including annex M*

IDN/SP/L/3, *Specification for procurement of line pipe for use in European onshore natural gas transmission and distribution pipelines (Supplement to EN ISO 3183)*

P2, *Specification for welding of land pipelines and installations designed to operate at pressures greater than 7 bar (supplementary to BS 4515-1)*

P8, *Specification for welding of steel onshore natural gas installations designed to operate at pressures greater than 7 bar*

2.5 Statutes and Regulations

Control of Substances Hazardous to Health (COSHH) Regulations 2002

Chemicals (Hazard Information and Packaging for Supply) Regulations 2009

Convention Covering International Carriage by Rail - International Carriage of Dangerous Goods by Rail 2015

International Carriage of Dangerous Goods by Road (ADR 2017)

The Carriage of Dangerous Goods and Use of Transportable Pressure Equipment Regulations 2012

Environmental Protection Act - EPA - (Duty of Care) 1991

Health and Safety at Work etc. Act 1974 and other relevant legislations, such as European Union (EU) if applicable

Regulation (EC) No 1907/2006 of the European Parliament and of the Council on the Registration, Evaluation, Authorisation and Restriction of Chemicals (REACH)

2.6 Bibliography

ISO 3183, *Petroleum and natural gas industries — Steel pipe for pipeline transportation systems*

ISO 13623, *Petroleum and natural gas industries — Pipeline transportation systems*

ISO 14001, *Environmental management systems — Requirements with guidance for use*

ISO/TS 29001, *Petroleum, petrochemical and natural gas industries — Sector-specific quality management systems — Requirements for product and service supply organizations*

DNV-RP-F111, *Interference between trawl gear and pipelines*

NOTE

Where no date is shown, the latest edition of each standard and specification shall apply.

- Gas Transporters will each have their own procedures & specifications normally in the referenced format */SP/XX/No, where * is replaced by the Gas Transporters reference e.g. T for National Grid, or SGN, WWU etc. followed by the specification initials and number reference.

3. Terms and Definitions

Aligned with ISO 21809-5, Clause 3 & 4.

4. Health, Safety and Environment

See Annex A and Clause 2.5 of this specification for guidance.

5. Quality

See Annex B of this specification for guidance.

6. General Requirements

6.1 Rounding

Compliance with ISO 21809-5, Clause 5.1.

6.2 Compliance with this document

Compliance with ISO 21809-5, Clause 5.2.

Compliance with Annex A and B of this specification.

7. Information Supplied by Purchaser

Compliance with ISO 21809-5, Clause 6.

8. Materials

Compliance with ISO 21809-5, Clause 7.

Typical pipe API and corresponding ISO designations are given in Table 1. Pipes may be requested in accordance with other standards such as BS EN 10255.

Table 1 – Steel Pipe Designations

API 5L	B	X42	X46	X52	X60	X65	X70	X80
ISO 3183 or T/SP/PIP/1 or IDN/SP/L/3	L245	L290	L320	L360	L415	L450	L485	L555

9. Concrete Mix

Compliance with ISO 21809-5, Clause 8.

10. Coating Application

Compliance with ISO 21809-5, Clause 9.

The following deviations shall apply:

1. Preparation of compressive strength specimens from fresh concrete (referenced ISO 21809-5, Clause 9.1, Table 1) omit.
2. ISO 21809-5, Clause 9.1, Table 1 - Concrete coating density shall be 'no less than 95% nominal'.
3. The process shall not damage the anti-corrosion coating.
4. Concrete shall not be applied until it is thoroughly mixed.
5. Cathodic protection – anode installation – see Annex C.
6. Buckle arresters – see Annex D.

11. Curing Methods

11.1 General

Compliance with ISO 21809-5, Clause 10.

If a plastics membrane is wrapped around the concrete coating as part of the curing process, this membrane shall be removed on completion of curing before dispatch of the coated pipe from the Contractor's premises.

11.2 Steam curing

If steam curing is to be used as part of the process, the Contractor shall demonstrate that the process will have no deleterious effects upon the concrete. The temperature shall not be allowed to be such that it would cause damage to any anti-corrosion coating on the pipes.

If steam curing is to be applied, it shall be commenced within a period of 2 to 4 hours after concrete application.

During the period prior to steam curing, the concrete on the pipes shall not be subjected to temperatures outside the range 5°C to 25°C, nor shall the surrounding relative humidity be outside the range of 80% to 100%.

A procedure shall be established to ensure that satisfactory conditions prevail until steam curing is applied.

Extreme care shall be given to transporting, moving or lifting pipes until the steam curing is complete.

Steam shall be applied until the concrete has achieved a compressive strength of 15MPa. This shall be proven by testing a set of three test cubes prepared at the same time as the pipes are coated and cured alongside the pipes. The frequency of cube preparation and testing shall be a part of the procedure ensuring correct curing until steam is applied. The temperature of the pipe or coating shall be not higher than 75°C at any time during the curing cycle.

The coated pipes in the curing bay shall be supported on the exposed ends of the steel pipes such that all the concrete coating is subject to the steam cure. Pipes shall be adequately restrained against rolling and shall not contact each other.

Appropriate thermometers and hygrometers shall be provided and records of readings shall be made available to the Gas Transporter.

12. Inspection and Testing

Compliance with ISO 21809-5, Clause 11.

The following deviations shall apply:

1. Preparation of compressive strength specimens from fresh concrete (referenced Table 2) omitted.
2. ISO 21809-5, Clause 11.1, Table 2 - Concrete coating density shall be 'no less than 95% nominal'.
3. ISO 21809-5, Clause 11.1, Table 2 – cement content & water / cement ratio (reference ISO 21809-5 Clause 8). At the Gas transporters discretion testing at a reduced frequency should be considered. The minimum frequency shall be 2 tests per day.
4. Test procedure anodes and attachments – see Annex C.
5. Test procedure Buckle arresters – see Annex D.

13. Repair of Coated Pipe

Compliance with ISO 21809-5, Clause 12.

14. Markings

Compliance with ISO 21809-5, Clause 13. The contractor may propose marking variants aligned with industry best practice for consideration.

15. Handling, Storage and Transport

Compliance with ISO 21809-5, Clause 14.

Storing of concrete coated pipes in the open shall not be permitted at temperatures lower than 1°C unless the coating has aged sufficiently to ensure a minimum compressive strength of 15MPa.

Checks shall be made to ensure that curing takes place in air temperatures in the range of 3°C to 35°C for the first seven days. After seven days, a minimum temperature of -3°C is permissible. Should the temperature fall below -3°C during the period seven days to 28 days, strength checks shall be carried out.

After 28 days no storage temperature limits apply.

Precautions shall also be taken to avoid sudden temperature changes which could cause the concrete to crack.

16. Test reports

Compliance with ISO 21809-5, Clause 15 and Annex B.

Annex A – Health, Safety & Environment

Health & Safety



All work carried out on the Plant or Site shall comply with safe working practices and the specific conditions of a Permit to Work

Contractor shall ensure that all activities involved in the selection, application, inspection and testing of protective coating systems are managed to ensure personnel safety, minimal environmental impact and safe, operable facilities including but not limited to:

- i. Implementation of safety measures for protecting workers in accordance with all local and national regulations including provision of appropriate personal protective equipment and training in its use, regular safety briefings/tool-box talks etc. Operations covered in this Specification are subject to the Health and Safety at Work etc. Act 1974 and other relevant legislations, such as European Union (EU) if applicable;
- ii. Implementation of appropriate training schemes to ensure personnel have necessary competence to perform their allocated tasks;
- iii. Development of method statements and risk assessments for potentially hazardous activities.
- iv. Provision of MSDS for all materials;
- v. All activities concerning substances shall have been subjected to an assessment under the Control of Substances Hazardous to Health (COSHH) Regulations 2002;
- vi. Provision of adequate ventilation and extraction facilities in confined spaces to prevent the build-up of toxic or flammable atmospheres, dust etc;
- vii. Provision of appropriate Personal Protective Equipment (PPE) including breathing and hearing protection.
- viii. Provision of appropriate breathing and hearing protection;
- ix. Provision of adequate access/scaffolding/working platforms in accordance with the Gas transporters procedure if relevant;
- x. Provision of adequate access and secure, temporary formwork to ensure safe working environments below grade; in accordance with Gas transporters procedure if relevant;
- xi. Provision of adequate safety systems to prevent electric shock and build-up of static electricity;
- xii. Provision of appropriate safety systems for use of pressurised air, including test certificates, 'dead-man' handles, whip-checks;
- xiii. Provision of appropriate fire-fighting equipment and personnel training in the use of equipment;
- xiv. Provision of appropriate first aid facilities;
- xv. Adherence to local hazardous/flammable area classification restrictions;
- xvi. Adherence to appropriate permit-to-work system requirements, including adequate training of personnel in their use;
- xvii. Provision of appropriate waste disposal and/or recycling systems to meet all local, national and international requirements.

Environment

Contractor shall ensure that manufacturing and application processes, and any associated materials and substances, do not constitute a toxic, microbiological or organoleptic hazard.

Any Hazard including toxic, corrosive risks and fire risks, associated with the coating materials offered for use to meet the requirements of this specification and associated with the method of application of the product shall be specified by the manufacturer, together with his recommendations for safe handling in accordance with the European Agreement concerning the International Carriage of Dangerous Goods by Road (ADR 2017) Appendix C of the Convention Covering International Carriage by Rail - International Carriage of Dangerous Goods by Rail. The Carriage of Dangerous Goods and Use of Transportable Pressure Equipment Regulations 2009 and the general principles of classification and labelling for supply are explained by the European Regulation (EC) No 1272/2008 on classification, labelling and packaging of substances and mixtures (CLP) on classification, labelling and packaging of substances and mixtures. Seek further guidance from HSE where required.

Materials and substances shall not contain asbestos, heavy metals (such as lead or cadmium), PCBs, CFCs and Halon refrigerants, nor VOCs or isocyanates in excess of local, national and international legal limits.

Provision of appropriate waste disposal and/or recycling systems to meet all local, national and international requirements such as the Environmental Protection Act - EPA - (Duty of Care) 1991.



Contractor shall ensure that manufacturing and application processes, materials and substances do not constitute a toxic, microbiological or organoleptic hazard.

Guidance note: *Isocyanates are typically present during the manufacture and application of polyurethane coating systems – these are potential carcinogens and their use is discouraged however, Company recognises that isocyanate-free coating systems with relevant service experience are currently limited therefore strict adherence to applicable regulations and use of personal protective equipment when handling or applying polyurethane coating systems shall be observed.*

Regarding the use of chromate-based pre-treatments for fusion bonded epoxy coating, hexavalent chromium has now been prohibited in Europe under REACH. Their use is prohibited.

Annex B – Quality

The Contractor shall have an accredited Quality and Environmental Management System that complies with a National or International Standard applicable to their service or supply. The quality system shall be based upon recognised quality standards of which ISO 9001 is a suitable example.

Guidance note:

- i. ISO/TS 29001 gives sector-specific guidance on quality management system;
- ii. ISO 14001 gives guidance on the selection and use of an environment management system.

A quality assurance group shall have been established, which shall be responsible for reviewing the quality system and ensuring that it is implemented.

Training, experience and competency records for all operatives involved in coating operations shall be maintained and available upon request.

The following competencies are acceptable:

- ICorr Pipeline Coatings Inspector - Level 2;
- NACE Coating Inspector Program - Level 2 & 3;
- Frosio - Level 2 & 3;
- BGAS-CSWIP Site and or Paint Coating Inspector.

Application and test procedures, which comprise the quality system and the ITP shall be submitted to the Gas Transporter for agreement.

The Gas Transporter shall if required make any investigation necessary in order to be assured of compliance by the Contractor and third parties and to reject any material and/or coating that does not comply.

A quality plan and ITP for the activities necessary to satisfy the requirements of this Specification shall be prepared and issued to the Gas transporter for agreement before commencement of work.

The quality plan and ITP shall:

- i. include any sub-contracted work and the subcontractor's quality plans shall be submitted;
- ii. be sufficiently detailed to indicate sequentially, and for each discipline, the requisite quality control, inspection, testing, and certification activities with reference to the associated procedures and the acceptance standards;
- iii. with due notice, be subject to formal audits by the Gas Transporter. The application of quality control may be monitored by the Gas Transporter or nominated third-party inspectors, who will witness and accept on behalf of the Gas Transporter the inspection, testing, and associated work required by this Specification.

The provision of inspection services reporting directly to the Gas transporter shall in no way relieve the responsibility to verify that the full scope of work is performed entirely in accordance with this Specification and the agreed quality plan and ITP.

The contractor shall issue testing and inspection reports to the Gas Transporter in accordance with ISO 10474.

The contractor shall issue qualification test reports, certificates of compliance for the coating in accordance with the requirements of this Specification and cited parts of ISO 21809-9; and any other requirements specified in the purchase order.

Annex C - Cathodic Protection - Anode Installation

1. General

Where cathodic protection is provided by the use of sacrificial anodes, design details of anodes should be specified by drawings provided by the Gas Transporter. Alternatively, the Gas transporter may request expert advice from the Contractor. The composition and permissible defects in anode material is of particular importance.

Anode materials shall be carefully handled, transported and stored to prevent damage, overstressing or surface contamination. Methods for the lifting and locating of anodes shall be such that they cannot be damaged or cause damage to the anti-corrosion coating of the pipes.

If anodes are to be installed after the application of the concrete coating, pipes assigned for anode installation shall have a section of concrete removed of such a length as to accommodate an anode +100 mm minimum and at the location as agreed in the purchase order.

1.1 Anode materials

Zinc or aluminium alloy anodes shall be used. Where the temperature of the anode is required to be higher than 50°C, only aluminium alloys shall be used. Where aluminium alloys are used, consideration of the operating environment shall be made so that the most suitable alloy is selected.

1.2 Anode attachments

Where anodes are required, they shall be securely attached to the pipe and adequately electrically bonded.

Any fillet welding associated with these attachments shall comply with the relevant clauses of P2.

1.3 Anti-corrosion coating of anode fixings

After the anode attachments and subsequent electrical continuity tests have been satisfactorily completed, the areas of pipe from which the coating was removed to make the connections and for the attachment of mechanical fittings, shall be coated in accordance with the relevant coating specification.

All areas of coating which have incurred any damage during the attachment of the fittings shall be removed and the exposed areas of pipe recoated in accordance with the relevant coating specification.

No anti-corrosion coating material shall be allowed to remain on the outer surface of the anodes. Removal of extraneous matter is the responsibility of the Contractor and shall be carried out without removing anode material and in a manner that causes no damage to either the anode or the pipe.

1.4 Concrete coating of pipes with fitted anodes

The reinforcement shall stop short of the anode bracelet face by not less than 50mm. The maximum distance is controlled by the design detail and the requirement that reinforcement shall stop short of the concrete chamfer. This shall also apply to any other metallic mesh used in the concrete coating application process.

Protection of the anode, prior to concrete coating, shall be effected by the use of suitable material (e.g. timber) and shall remain in place for future protection during transit.

To eliminate voids, gaps between anode sections shall be filled with a suitable material as agreed by the Gas Transporter and Contractor.

Anodes shall be electrically isolated from all reinforcement and anode faces shall be electrically insulated where they abut concrete coatings which contain metallic ores.

2. Test procedures - Anodes and attachments

2.1 Visual inspection

Each anode shall be checked for correct positioning and location. Repairs to the anti-corrosion coating and concrete application shall also be checked at the appropriate stage.

2.2 Welding

The welding design shall be such that all joints are fully sealed and there are no areas where crevice corrosion can occur. There shall be adequate access for the welder to ensure fully sealed welds. Welding shall be carried out to either P2 or P8 as appropriate.

2.3 Electrical continuity

Records of the test results for electrical continuity of the anode and pipe shall be maintained and the tests carried out using an ohmmeter of the Bridge Megger type (or other similar null balance indicating instrument). The resistance value measured between the anode and the pipe shall be not be greater than 0.05Ω .

2.4 Causes for rejection

Coated pipes shall be rejected if anodes and fixings have any of the following defects:

- i. Damage to anodes;
- ii. Defective welds;
- iii. Electrical isolation not as specified;
- iv. Electrical continuity resistance greater than specified;

Annex D - Buckle Arresters

1. General

Where buckle arresters are required, they shall be of a type to suit the particular requirements. Specific requirements shall be indicated on drawings prepared by the Gas Transporter or proposed by the Contractor.

The Contractor's proposed method for fixing the arrester to the pipe shall be submitted to the Gas Transporter prior to this work being carried out.

1.1 Material

Buckle arresters, if welded to the main pipe, shall be of carbon manganese steel compatible with the specified pipe. For other forms (i.e. not welded to the pipe), relaxation of this requirement may be proposed as a variant for consideration by the Gas Transporter. The minimum yield strength and ductility shall be evaluated by the Gas Transporter and Contractor and agreed.

1.2 Buckle arrester

The buckle arrester shall preferably be of the following types, as appropriate:

- i. thick wall section of pipe, integral with the pipe (see Figure 1);
- ii. external sleeve with grout between sleeve and pipe (see Figure 2).

Other methods may be proposed as a variant for consideration by the Gas Transporter.

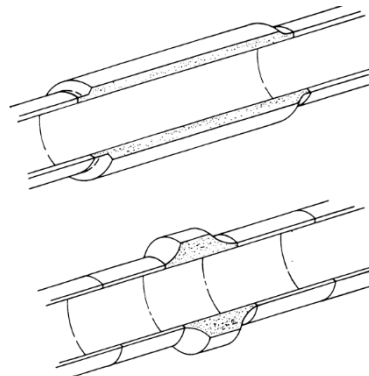

Figure 1 – Typical example of thick wall arrester

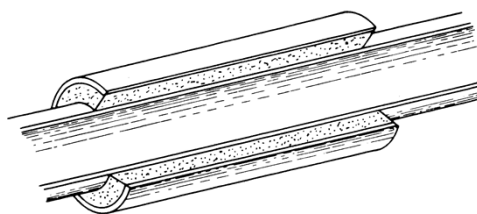

Figure 2 – Typical example of grouted buckle arrester

1.3 Dimensions and tolerances

The grouted sleeve type of buckle arrester shall be sized so that the gap between the anti-corrosion coating and the internal diameter of the sleeve, when concentrically located, shall be as follows:

- a) for pipes equal to or less than 750 mm: 25 +10, -0 mm;
- b) for pipes greater than 750 mm: 40 +10, -0 mm.

The length and wall thickness will be dependent on the diameter of the pipe. Specification shall be agreed by the Gas Transporter and Contractor.

1.4 Welding

Welding of thick wall buckle arresters to Figure 1 shall be carried out in accordance with the requirements of P2. The metallurgy of the pipe and fitting may dictate the use of low hydrogen welding electrodes.

Sleeves for grouted buckle arresters to Figure 2 shall be made either from pipe complying with API 5LX or equivalent and welded in accordance with P8, or fabricated and welded in accordance with the following requirements

- i. The welding procedure shall be designed to ensure that the completed weld is compatible with the plate material as far as chemical composition and tensile properties are concerned;
- ii. The hardness of the weld shall be not greater than 330 HV 10 (when tested in accordance with the requirements of BS 427);
- iii. The impact strength of the weld material shall be not less than 27 J at 0 °C (when tested in accordance with the requirements of BS EN 10045-1);
- iv. The welding procedure shall comply with the requirements of BS 5135.

1.5 Electrical isolation of grouted buckle arrester

When a buckle arrester is positioned and grouted it shall be electrically isolated from the pipe. This isolation shall be tested with a calibrated instrument. The resistance shall be greater than 10 000 Ω.

1.6 Anti-corrosion coating

The exposed surfaces of the buckle arrester shall be protected from corrosion by a suitable anti-corrosion coating. The type, thickness, surface preparation and application shall be specified by the Gas Transporter. For grouted buckle arresters, the process shall preferably be carried out after the grouting process.

1.7 Grouting

The Contractor shall demonstrate that the grouting is homogeneous and that the arrester is concentric with the axis of the pipe within the permissible tolerances given by Annex D, Clause 1.3.

The type of grout to be used shall be agreed upon by the Gas Transporter and Contractor.

The grouting material shall be prepared in accordance with the manufacturer's written specification and the grouted volume shall be of suitable viscosity and free from voids.

Test samples shall be taken during grouting operations in accordance with ISO 21809, Clause 11 to assess the suitability of the mix. The acceptable compressive seven-day strength of the grout shall be not less than 15 MPa.

1.8 Thrust bore coatings – Butt joints

If butt joints are required in a length of pipe to be thrust bored, it is not essential for the infill to be of concrete. A suitable coating system / procedure, selected from GIS/CW5 or GIS/CW6, for the

protection of the butt weld area is required. At the gas transporters discretion an alternative certified system may be considered.

2. Test Procedures - Buckle arresters

The anti-corrosion coating on the pipe shall be inspected for holidays or other damage before positioning a sleeve type buckle arrester. Any holiday or damage detected within the zone of a grouted sleeve buckle arrester shall be repaired, inspected and retested in accordance with the relevant coating specification before the sleeve is fitted.

Before being placed on the pipe, each buckle arrester shall be inspected to ensure that dents, scratches, ovality or other damage has been rectified.

The quantity of grout filler used shall be checked using a volumetric technique and compared with the calculated cylindrical volume to be filled.

Grout strength shall be checked for each buckle arrester using test cubes which shall meet the minimum acceptable results as specified in Appendix D, Clause 1.7.

A suitable anti-corrosion coating shall be applied to the buckle arrester. The system may be applied and tested in accordance with either GIS/CW5 or GIS/CW6 as appropriate; or at the discretion of the Gas Transporter an alternate certified coating system may be considered.

Both the pipe and the buckle arrester, after anti-corrosion coating, shall be subjected to a further holiday detection test in accordance with the relevant specification.

2.1 Causes for rejection

Coated pipes shall be rejected if grouted buckle arresters have any of the following defects:

- i. Concentricity not in accordance with the requirements of this Specification;
- ii. Electrical isolation not as specified;
- iii. Incorrect mixing resulting in incorrect viscosity of grouting material;
- iv. Incorrect temperature;
- v. Insufficient grout used to fill the interspace. The quantity of grout filler used shall be not less than 95% of the calculated volume.

If the coated pipe is rejected, grout filling and buckle arrester shall be removed and replaced correctly. The grout shall be removed in such a manner as to avoid damaging the anti-corrosion coating on the pipe.