



Engineering Recommendation L44

Issue 1 2012

Separation between Wind Turbines and
Overhead Lines

Principles of Good Practice

PUBLISHING AND COPYRIGHT INFORMATION

© 2012 *Energy Networks Association*

All rights reserved. No part of this publication may be reproduced, stored in a retrieval system or transmitted in any form or by any means, electronic, mechanical, photocopying, recording or otherwise, without the prior written consent of Energy Networks Association. Specific enquiries concerning this document should be addressed to:

**Operations Directorate
Energy Networks Association
6th Floor, Dean Bradley House
52 Horseferry Rd
London
SW1P 2AF**

This document has been prepared for use by members of the Energy Networks Association to take account of the conditions which apply to them. Advice should be taken from an appropriately qualified engineer on the suitability of this document for any other purpose.

First published, August 2012

Amendments since publication

Issue	Date	Amendment

Contents

Foreword	2
Introduction	3
1 Scope	4
2 Normative references	4
3 Terms and definitions	5
4 Separation Between Wind Turbines and Overhead Power Lines	5
4.1 Toppling Distance	6
4.2 Wake Effects	6
4.2.1 Prevailing Wind Direction & Frequency (affects likelihood).....	6
4.2.2 Relative Positions and Dimensions of Turbine and Line (affects likelihood)	7
4.2.3 Line Design (affects consequence)	7
4.2.4 Availability of Mitigation Measures (affects consequence).....	7
4.2.5 System Considerations (affects consequence)	7
5 Construction and Maintenance issues	8

Figures

Annex A: Diagrammatic representation of rotor diameter.....	9
Annex B: Diagrammatic representation of falling clearances	10
Annex C: Wind turbine wake diagrams	11

Tables

Table 1 Toppling Clearances.....	6
----------------------------------	---

Foreword

This engineering recommendation is published by the Energy Networks Association (ENA) and comes into effect from 1st August 2012. It has been prepared under the authority of the ENA Engineering Policy and Standards Manager.

This engineering recommendation has been compiled by the ENA Overhead Lines Panel in consultation with Renewable UK. The recommendation is based on national guidelines and research and may be varied to suit specific local applications.

Introduction

Renewable energy is becoming an increasing part of the UK energy production. Wind energy has now become the largest renewable generation source in the UK.

UK Transmission and Distribution companies are required to demonstrate network resilience under their license conditions and to comply with the requirements of the Electricity Supply, Quality, and Continuity Regulations (ESQCR)

This Engineering Recommendation has been produced to present a set of generic principles of “Best Practice” for both Electricity Network Operators and Wind Farm Developers for use when locating wind farms and stand-alone turbines in the vicinity of overhead lines or vice versa. It is not intended to be used as a fixed, standard set of criteria which are binding on all parties.

Wind farm developers and Electricity Network Operators are encouraged to open dialogue with each other to resolve any potential issues at the initial development stage

1 Scope

This Engineering Recommendation shall apply to all designs of wind turbines and overhead lines of all voltages

The Engineering Recommendation considers three principle areas:

- Toppling distances of wind turbines
- Wake effects on overhead lines
- Construction and Maintenance issues

Building mounted turbines are not covered by this document and clearances of these to overhead power lines shall be based on the requirements defined in ENA Technical Specification 43-08, (*Clearances to Objects criteria*).

2 Normative references

The following referenced documents, in whole or part, are indispensable for the application of this document. For dated references, only the edition cited applies. For undated references, the latest edition of the referenced document (including any amendments) applies.

Standards publications

ENA TS 43-08 Overhead line Clearance

Other publications

HSE GS6 – Avoidance of Danger from Overhead Lines

Planning Policy Statement (England & Wales) PPS 22 - Renewable Energy

Planning Policy Statement (Scotland) SPP 6 - Renewable Energy

Guidelines for Onshore and Offshore Wind Farms. (Health & Safety in the Wind Energy Industry Sector 2010). Published by RenewableUK

3 Terms and definitions

For the purposes of this document, the following terms and definitions apply.

3.1 - Overhead line

An Electric Line in the open air and above ground level conforming to the definition contained in the ESQCR 2002

3.2 - Wind Turbine

A free standing structure which uses wind driving a set of rotating blades (Horizontal and Vertical axis machines)

3.3 - DNO

Distribution Network Operator

3.4 - TSO

Transmission System Operator

3.5 - Tip height (Ht)

For free standing turbines, Ht equals the highest point from the ground scribed by the rotation of a wind turbine blade (or similar object).

3.6 – Rotor Diameter (D)

For horizontal axis machines, D equals the circle inscribed by the blade tips

For vertical axis machines, D equals the diameter of the cylinder.

See Annex A

4 Separation Between Wind Turbines and Overhead Power Lines

There are two criteria, described in more detail below that will determine the recommended minimum separation of wind turbines and overhead power lines:

- The turbine should be sufficiently distant to avoid the possibility of toppling onto the overhead line.
- The turbine should be sufficiently distant to avoid causing damage to the overhead line due to downwind wake effects.

These criteria are described in more detail below, with consideration of issues that include: prevailing wind direction and frequency, relative geometry of turbine and line, line design, mitigation measures, and wider system impacts.

It is accepted by DNO's and TSO's that if both of the above criteria are met, then the turbine position shall be deemed acceptable. If either, or both, criteria are not met, then contact should be made with the appropriate network owner to establish the suitability of any proposed turbine location.

4.1 Toppling Distance

Wind turbines shall be positioned such that the minimum horizontal distance from the worst-case pivot point of the wind turbine and the overhead line conductors hanging in still air is the greater of:

- The tip height of the turbine (Ht) + 10%
- The tip height of the turbine (Ht) + the electrical safety distance (Lc), applicable to the voltage of the overhead line and given in Table 1

Electrical clearance (Lc) in still air is based on the criteria used for street lighting columns in ENA TS 43-08:

System Voltage (kV)	≤33	66	132	275	400
Electrical Safety Clearance (Lc) for Turbines Falling towards line with conductor hanging vertically	1.7m	1.9m	2.3m	3.3m	4.0m

Table 1 Electrical Safety Toppling Clearance (Lc)

This situation is illustrated in Annex B.

4.2 Wake Effects

The wake downwind of a wind turbine could have significant effects on overhead line conductors, potentially causing increased levels of motion and, in extreme cases, conductor clashing.

Current research by National Grid and other international bodies has shown that at distances greater than three rotor diameters from the turbine these effects are negligible. Within three rotor diameters distance behind the turbine, there may be an increased risk of wind-induced conductor motion, which would lead to increased wear and/or fatigue damage and consequent shortening of the overhead line's asset life.

This increased risk will depend on several factors, so a turbine positioned within three rotor diameters of an overhead line may be deemed acceptable (provided the toppling distance is maintained) following a risk assessment and (if applicable) the use of mitigation measures such as vibration control devices. In order to aid overhead line asset owners in assessing the likely risk, the following is a qualitative description of the various parameters that should be considered. A quantitative approach, while preferable, is not practical due to the large number of variables, including an asset owner's interpretation of acceptable risk levels.

Starting from the basic principle that *risk = likelihood x consequence*:

4.2.1 Prevailing Wind Direction & Frequency (affects likelihood)

Clearly the downwind wake of a wind turbine can only impact on a nearby overhead line if the line is actually downwind of the turbine. This will never be 100% of the time, with the likelihood of being downwind dependent chiefly on the wind pattern at the relevant geographical location. Many wind power installations are preceded by wind monitoring, with a "wind rose" being generated to aid in the design of the installation. This information, if available, is ideal for use in determining a line's potential exposure to wake effects.

4.2.2 Relative Positions and Dimensions of Turbine and Line (affects likelihood)

Even if an overhead line is downwind of a wind turbine, it is not necessarily the case that the line will be exposed to the aerodynamic wake of the turbine. Whether the structures or conductors are within the wake will depend on the relative position of the turbine, dimensions of the turbine, the shape of the down-wind wake field and topography. For example, a turbine with an 80m hub height and 90m rotor diameter is unlikely to affect a line carried by 10m wood poles, but the same turbine may present a risk to an overhead line supported by 60m steel towers.

This wake effects are illustrated in Annex C

4.2.3 Line Design (affects consequence)

Items 4.2.1 and 4.2.2 above relate to the likelihood of a line being exposed to the wake effects of a turbine installation. In order to assess the likely consequence of exposure, certain aspects of the line's design should be considered, such as span length and conductor configuration. The impact of downwind effects will differ depending on whether just part of span is exposed, or whether a whole span is exposed. In addition, the behaviour of single conductors in wind is different to the behaviour of bundled conductors.

It is not the intention of this document to describe wind-induced motions of overhead line conductors in detail, but in very broad terms, the consequence of turbine wake effects on lines with single conductors per phase and full spans exposed to the wake are likely to be quite limited, whereas lines utilising bundled conductors and and/or where only part of the span is exposed to the wake may experience very different modes of oscillation and motion..

The extent, to which measures are already in place to protect the line from wind turbulence, for instance around forest edges or near motorways, needs also to be considered.

4.2.4 Availability of Mitigation Measures (affects consequence)

Line design not only affects the likely impact of wake effects, but also the mitigation measures that can be employed to combat them. Mitigating the effects of motion can take many forms, and might involve replacing spacers, changing the way a conductor is attached to support structures, or employing motion control devices. The practicality of employing such measures is very variable, and each case would need to be assessed on its own merits..

4.2.5 System Considerations (affects consequence)

Finally, the age, condition, and importance of the overhead line as part of the wider electrical network should be considered.

5 Construction and Maintenance issues

Wind turbine construction and maintenance activities shall be in general compliance with the existing requirements laid down in Health and Safety Executive document GS6.

There is a variety of Health and Safety guidance available on the construction and maintenance of wind turbines. For Example “Guidelines for onshore and Offshore wind farms”, published by RenewableUK. <http://www.bwea.com/pdf/HSguidelines.pdf>

Further to section 4, when considering separation distances less than $3xD$, maintenance access requirements for both the turbine and overhead line shall be considered when determining separation requirements.

The companion guide to Planning Policy Statement 22, should also be considered

Annex A:
Diagrammatic representation of rotor diameter

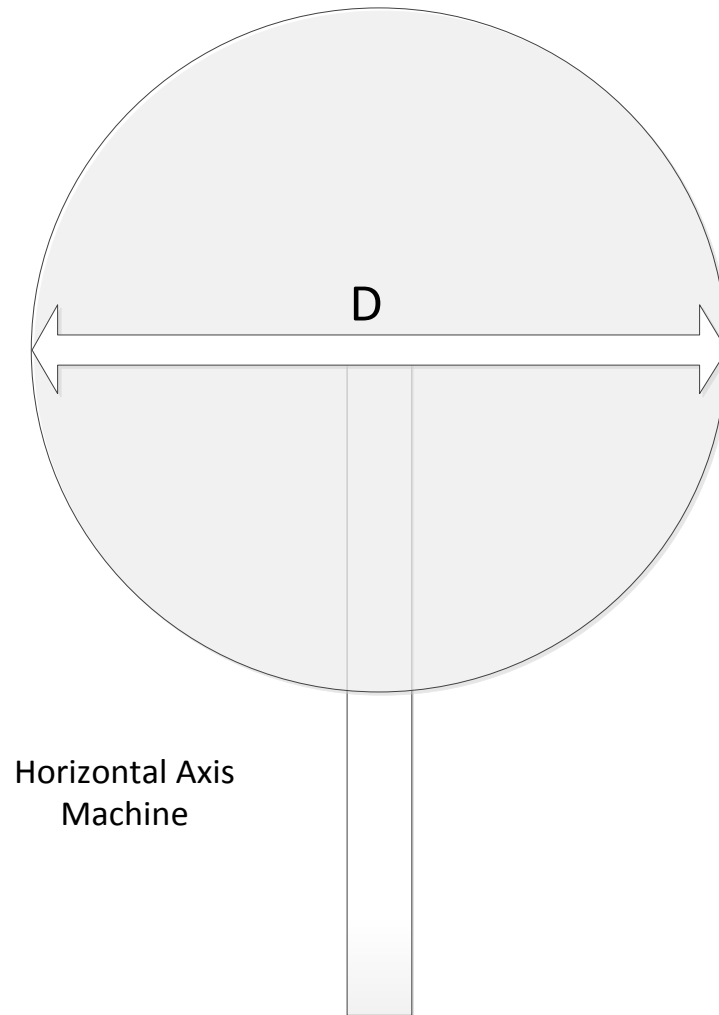

Horizontal Axis
Machine

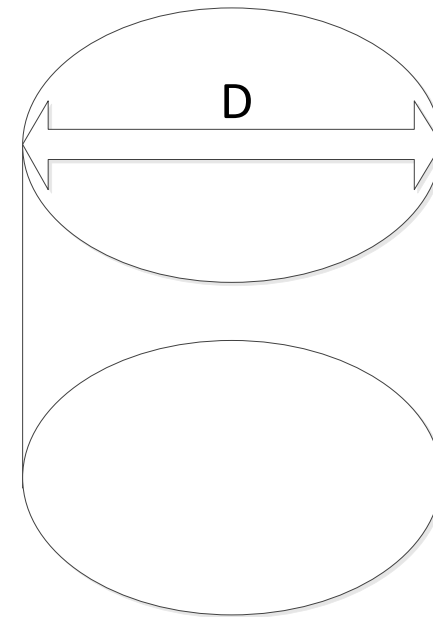

Vertical Axis
Machine

Annex B:
Diagrammatic representation of falling clearances

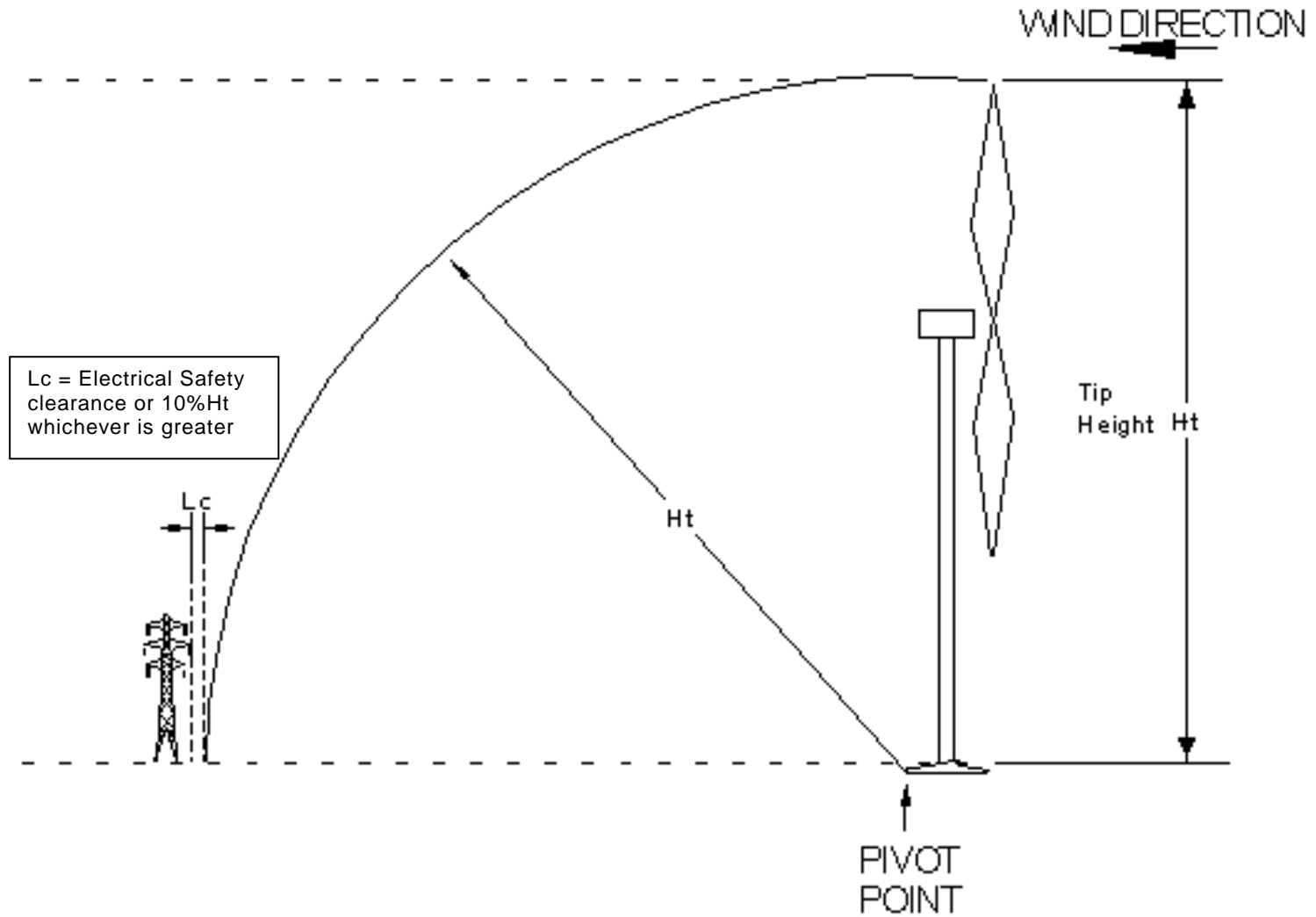

Not to scale

Annex C: Wind turbine wake diagrams

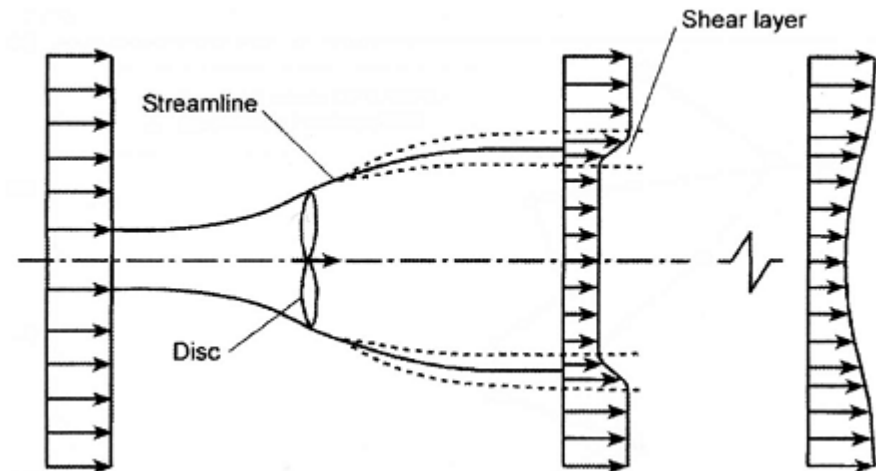
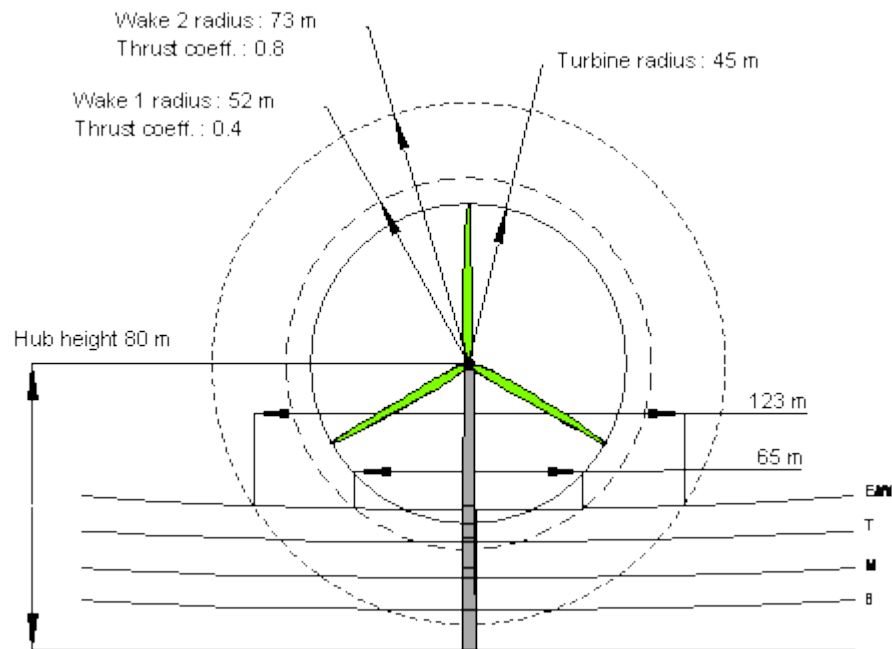

Not to scale